

EUROSTYLE COLLECTION

- WALL MOUNT
- PHOTOCELL AVAILABLE ON SELECT MODELS
- MOLDED OF DURABLE NON-CORROSIVE UV RESISTANT PLASTICS
- ASSEMBLED OR KNOCKED DOWN



SPECIFICATIONS

- UL LISTED FOR WET LOCATIONS
- INCANDESCENT MODELS 120V; FLUORESCENT MODELS 120V NPF
- POLYCARBONATE DIFFUSER & BASE
(COMMERCIAL MODELS USE POWDERCOATED ALUMINUM BASE)
- STANDARD PACK QTY: 6 MOQ: 72

EUROSTYLE OVAL GRID

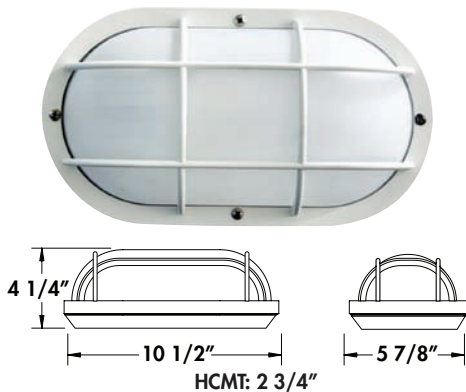

POLYCARBONATE BACK PAN



COMMERCIAL GRADE EUROSTYLE OVAL GRID

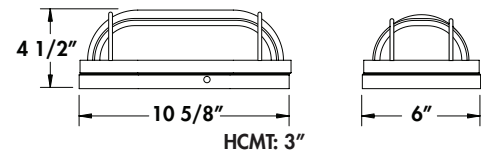

ALUMINUM BACK PAN

EXAMPLE # **FE104-I60-BF**

STYLE #	WATTAGE	BODY	DIFFUSER	OPTION
EUROSTYLE OVAL GRID				
FE104	I60 = 1-60W MEDIUM BASE INCANDESCENT LAMP ◊ M9 = 1-CFT9W/GX23 LAMPS (MAGNETIC) ◊ M13 = 1-CFT13W/GX23 LAMPS (MAGNETIC) G13 = 1-13W GU-24 LAMP (ELECTRONIC) G18 = 1-18W GU-24 LAMP (ELECTRONIC) G23 = 1-23W GU-24 LAMP (ELECTRONIC) G26 = 1-26W GU-24 LAMP (ELECTRONIC) E13 = 1-CFQ13W/G24q-1 LAMPS (ELECTRONIC) E18 = 1-CFQ18W/G24q-1 LAMPS (ELECTRONIC)	B = BLACK W = WHITE	F = FROSTED	
COMMERCIAL GRADE EUROSTYLE OVAL GRID				
FE114	M13 = 1-CFT13W/GX23 LAMPS (MAGNETIC) M213 = 2-CFT13W/GX23 LAMPS (MAGNETIC) G13 = 1-13W GU-24 LAMP (ELECTRONIC) * G213 = 2-13W GU-24 LAMPS (ELECTRONIC) * G18 = 1-18W GU-24 LAMP (ELECTRONIC) * G23 = 1-23W GU-24 LAMP (ELECTRONIC) * G26 = 1-26W GU-24 LAMP (ELECTRONIC) * E13 = 1-CFQ13W/G24q-1 LAMP (ELECTRONIC) * E213 = 2-CFQ13W/G24q-1 LAMPS (ELECTRONIC) * E18 = 1-CFQ18W/G24q-1 LAMP (ELECTRONIC) * E218 = 2-CFQ18W/G24q-1 LAMPS (ELECTRONIC) * E26 = 1-CFQ26W/G24 LAMP (ELECTRONIC) * E32 = CFTR32W/GX24q LAMP (ELECTRONIC) *	B = BLACK W = WHITE	F = FROSTED	P = PHOTOCELL

* ENERGY STAR COMPLIANT WHEN ORDERED WITH PHOTOCELL OPTION

◊ EXPLODED VIEW AVAILABLE ON CD

For more information regarding Inter-Global's Assembled Fixtures and Private Labeling please contact our sales department at **1-800-325-7364** or visit www.interglobal-inc.com

Specifications subject to change without notice. Printed in U.S.A. © 2011 Inter-Global Inc.



1101.1

E7